

Technical data sheet



Product features

High-capacity boiling kettle electric indirect 200 l

Model	SAP Code	00019665
--------------	-----------------	----------



- Device type: Electric unit
- Device heating type: Indirect
- Steam pressure regulation: Automatic - the pressure switch regulates the performance of the device
- Filling: Mechanical cock
- Jacket filling: Semi-automatic
- Drain valve diameter: 2"
- Basin volume [l]: 200
- Usable volume [l]: 183

SAP Code	00019665	Loading	400 V / 3N - 50 Hz
Net Width [mm]	1000	Basin volume [l]	200
Net Depth [mm]	928	Usable volume [l]	183
Net Height [mm]	900	Device heating type	Indirect
Net Weight [kg]	188.00	Steam pressure regulation	Automatic - the pressure switch regulates the performance of the device
Power electric [kW]	24.000		

Technical data sheet



Technical drawing

High-capacity boiling kettle electric indirect 200 l

Model	SAP Code	00019665
--------------	-----------------	----------

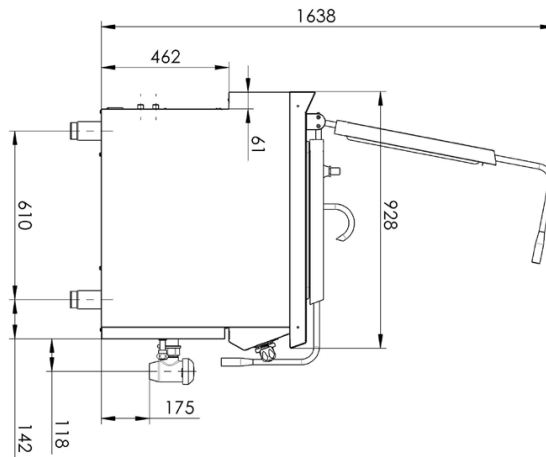
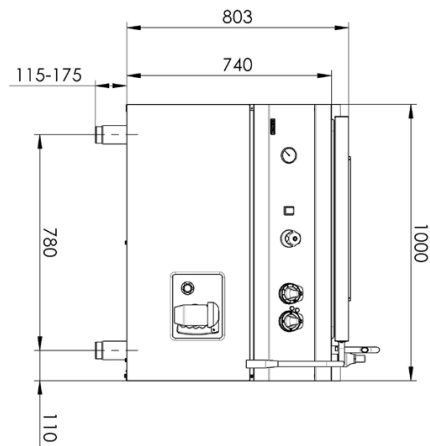

E - přívod napětí 400V
WD - přívod vody do duplikátoru
W - přívod vody

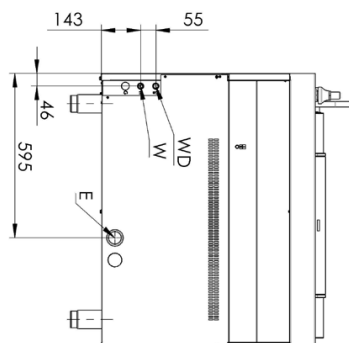

High-capacity boiling kettle electric indirect 200 l

Model

SAP Code

00019665

1

Top cover in front panel design

thanks to the design, the lines of the front panel and the lid are unified, the designed design allows easy maintenance by the user

- thanks to the design, the condensate is drawn to the back of the lid, eliminating the risk of scalding the operator with hot condensate; the user saves time and energy when maintaining the product

2

Ergonomic extended handle

even people of smaller stature can comfortably lift the lid to the fully open state

- the operator will not be scalded by steam when the lid is raised to the fully open position.

3

Sloped bottom for the sink

the entire volume of the container will flow out without the need to carry the food to the sink

- no residual puddles on the bottom of the cooking vessel; eliminates losses when food is poured out of the cooking vessel

4

Reinforced bottom without deformations

thanks to the reinforcements in the intermediate shell, the service life of the duplicator is extended, there is no deformation due to heat and expansion of the material

- several times longer life of the cooking vessel, where the reinforcements prevent tearing or deformation; the user does not have to replace the product with a new one after years of use, thus saving costs

5

Spill-resistant design controls

ergonomically comfortable, preventing water from entering the device

- due to the sufficient coverage of the controls, water does not leak into the device, thus prolonging the life of the control or eliminating the potential risk of leakage into the functional components of the device

6

Lines in the container

the operator knows at a glance how much food is inside the cooking vessel

- time-saving for the product operator when filling water or measuring the total quantity of food to be prepared

7

Duplicator automatic venting

thanks to the integrated pressure switch, the pressure in the intermediate casing is automatically regulated

- the user can concentrate on food preparation or ingredients as he does not have to monitor the pressure in the intermediate vessel.

8

Rotatable filling arm

convenient filling of the duplicator container, the hanger is used for maintenance and cleaning of the cooking container

- convenient filling and cleaning of the cooking vessel, but the hanger does not interfere with the cooking vessel, thanks to its position on the top plate

9

Integrated waste overflow

condensed water drains directly from the top plate

- elimination of the risk of the operator slipping on the wet floor; excess liquids are drained directly into the central waste and not in front of or under the equipment

10

Glass door

easier operation and cleanability, water does not flow over the edge on controls and service the top plate retains its stiffness without deformation over time due to use

- operator safety when using the product, hygiene and strength of the equipment

11

Integrated waste overflow

the operator can check the pressure in the intermediate casing

- the operator receives real-time information about the pressure in the intermediate layer and thus checks the correctness of the function and the efficiency of the energy used

12

A pre-prescribed upper lid with a lifting mechanism

lid holds open in different positions

- when partially opened, there is no large heat loss and thus energy savings are achieved

Technical data sheet



Technical parameters

High-capacity boiling kettle electric indirect 200 l

Model	SAP Code	00019665
--------------	-----------------	----------

1. SAP Code:

00019665

2. Net Width [mm]:

1000

3. Net Depth [mm]:

928

4. Net Height [mm]:

900

5. Net Weight [kg]:

188.00

6. Gross Width [mm]:

1035

7. Gross depth [mm]:

1030

8. Gross Height [mm]:

1085

9. Gross Weight [kg]:

196.00

10. Device type:

Electric unit

11. Construction type of device:

Stationary

12. Power electric [kW]:

24.000

13. Loading:

400 V / 3N - 50 Hz

14. Protection of controls:

IPX4

15. Exterior color of the device:

Stainless steel

16. Material:

AISI 304 top plate and cladding

17. Indicators:

operation and warm-up

18. Drain valve diameter:

2"

19. Worktop type:

Molded - comfortable cleaning maintenance

20. Worktop material:

AISI 304

21. Worktop Thickness [mm]:

2.00

22. Surface finish:

polished stainless steel

23. Device heating type:

Indirect

24. Basin volume [l]:

200

25. Device capacity [l]:

200.00

26. Maximum device temperature [°C]:

90

27. Minimum device temperature [°C]:

30

28. Service accessibility:

Trough the frontal panel

Technical data sheet



Technical parameters

High-capacity boiling kettle electric indirect 200 l

Model

SAP Code

00019665

29. Safety element:

manometer
long handle

30. Safety thermostat:

Yes

31. Safety thermostat up to x ° C:

150

32. Adjustable feet:

Yes

33. Bottom thickness:

2.50

34. Bottom material:

AISI 316

35. Type of pan:

Fixed

36. Usable volume [l]:

183

37. Filling:

Mechanical cock

38. Jacket filling:

Semi-automatic

39. Basin shape:

Practically shaped bathtub spout to minimize spillage

40. Steam pressure regulation:

Automatic - the pressure switch regulates the performance of the device

41. Type of drain valve:

conical

42. Overflow:

Yes

43. Manometer:

Yes

44. Water filling type:

Cold